

**CHANGE ORDER FORM
(ATTACHMENT A TO SPECIAL CONDITIONS)**

Project: District-Wide Emergency Call Station Project
 Date: February 8th, 2021
 Contractor: Electronic Innovations, Inc.

Change Order: #001
 PO Number: B210248

Pursuant to the General Conditions, this Change Order Form shall be used for all Change Orders associated with the Work. No additions or deletions to this form shall be allowed, except with permission of the District.

You are hereby directed to provide the extra work necessary to comply with this Change Order.

DESCRIPTION OF CHANGE:

Item #1 Cost Proposal #2 Procurement and installation of additional powered fiber equipment \$ 19,958.16

Total Items #1 through #1 \$ 19,958.16

PREVIOUSLY BILLED AGAINST \$70,000 OWNER ALLOWANCE	\$ 0.00
TOTAL TO BE BILLED AGAINST OWNER ALLOWANCE	\$ 19,958.16
REMAINING OWNER ALLOWANCE IN CONTRACT	\$ 50,041.84
BALANCE TO BE ADDED TO THE CONTRACT BY THIS CHANGE ORDER #1	\$ 0.00

Contractor accepts the terms and conditions stated as full and final settlement of any and all claims arising from this Change Order. Contractor agrees to perform the above described changes in accordance with the terms set forth herein and in compliance with applicable sections of the Contract Documents. This Change Order is hereby agreed to, accepted and approved, all in accordance with the General Conditions of the Contract Documents. The adjustment of the Contract Price and the Contract Time for the changes noted in this Change Order (the "Changes") represents the full and complete adjustment of the Contract Time and the Contract Price due the Contractor for providing and completing such Changes, including without limitation: (i) all costs (whether direct or indirect) for labor, equipment, materials, tools, supplies and/or services; (ii) all general and administrative overhead costs (including without limitation, home office, field office and Site general conditions costs) and profit; and (iii) all impacts, delays, disruptions, interferences, or hindrances in providing and completing the Changes. Contractor waives all rights, including without limitation those arising under Civil Code Section 1542, for any other adjustment of the Contract Price or the Contract Time on account of the Changes set forth in this Change Order or the Contractor's performance and completion of the Changes.

NOT VALID UNTIL SIGNED BY THE OWNER, ARCHITECT, AND CONTRACTOR

The original Contract Sum was \$ 1,306,899.00

Net change by previously authorized Change Orders \$ 0.00

The Contract Sum prior to this Change Order was..... \$ 1,306,899.00

The Contract Sum will be changed by this Change Order in the amount of..... \$ 0.00

The adjusted Contract Sum including this Change Order will be..... \$ 1,306,899.00

The Contract Time will be (increased) (decreased) (unchanged) by..... (81) Days

The date of Substantial Completion as of the date of this Change Order therefore is: . . . 7 / 28 / 21

ARCHITECT

CONTRACTOR

CONSTRUCTION
MANAGER

OWNER
CHABOT-LAS POSITAS COMMUNITY
COLLEGE DISTRICT
7600 Dublin Blvd., 3rd fl.
Dublin, CA 94568

Catalyst.

Electronic Innovations, Inc.

SWINERTON M & C

By: [Signature]

By: [Signature]

By: Michael Strand

By: _____

Date: 2/11/2021

Date: 2/10/2021

Date: 2/8/21

Date: _____

PM: _____

Recommended by:

District Project Planner/Manager

Vice Chancellor, Facilities
Facilities & Bond Programs CLPCCD

By: [Signature]

By: [Signature]

Date: 2/18/21

Date: 2/19/2021



21
Parr
Boulevard
RICHMOND
CALIFORNIA
94801
FACSIMILE:
510.232.3205
TELEPHONE:
510.233.2795

January 25, 2021

Michael Stroud
Project Manager
Swinerton Management & Consulting
Chabot-Las Positas Emergency Call Station Project
Contract Number: B20/20-02

Re: PCO #2 – CommScope Unlisted Components

Michael;

Attached to this cover is the breakdown of Sunflower Electric's Change Order for the Required CommScope Equipment that was unlisted and submitted in RFI-003.

Sunflower Electric Labor and Material	\$16,803.19
Sunflower 12% Markup	\$2,016.38
Sunflower Total Cost	\$18,819.57
Bonding Markup at 1%	\$188.20
Electronic Innovations Markup @ 5%	\$950.39

PCO Change Order Total: \$19,958.16

2.

Adam Henricksen
Installation Manager

Due to delay at Commscope, manufacturer of specified powered fiber equipment, the materials are not expected to arrive on site until February 25th. Contractor and CM have agreed to noncompensable time extension pushing the substantial completion date to July 28th, 2021.

Michael Stroud, Construction Manager
Swinerton Management and Consulting

Sunflower Electric

1485 Bayshore Blvd #196, Suite 406
San Francisco, CA 94124
Ph 415-859-5554

CHANGE ORDER

To:
Customer Electronic Innovations
Address 21 Parr Blvd
City Richmond CA 94801
Attn: Adam Henricksen

Date 1/20/2021
Job # S704
C/O # 18001.01
Contract _____
PCO # _____

Project:

Chabot - Las Positas Colleges

Mr./Mrs. Adam Henricksen

We are pleased to provide this proposal for the subject project. Please see the following scope of work.

Scope:

F/I Rectifier components per Sunflower RFI - 001, identified by Commscope representative Mungree Singh.

RESPONSE UPDATED 1/20/21

Updated Qty provided by others.

We understand the concern with qty of hours. Please consult attached installation instructions.

Sunflower has listed the 13 locations at 2 hrs additional labor per.

Equipment Caltrans/DOT Charges have been removed for this change order only.

Exclusions/Clarifications:

1 - All base bid exclusions and clarifications apply.

Total Pricing:

\$ 18,819.57

Sincerely,

Gordon C Burwell II

Gordon C Burwell II
Project Manager
Sunflower Electric
GBurwell@SunflowerElectric.net
C: (650) 281-9181
O: (415) 859-5554

Sunflower Electric

1485 Bayshore Blvd #196, Suite 406
San Francisco, CA 94124
Ph 415-859-5554

CHANGE ORDER

TRADE CONTRACTOR COST PROPOSAL FORM

This form is to be completed by each trade contractor and each lower tier trade contractor. Use additional sheets as necessary.

Contract No:	0	Date:	1/20/2021	
Project Name:	Chabot - Las Positas Colleges	PCO No:	0	
Trade Contractor Name:		Trade Contractor CO No:	S704	18001.01
HRC% of Change:		RFI/Submittal No:		
Description of Work				
See Page One: Scope				
Labor				
Name	Classification	Hours	Rate	Total
	Senior Tech	26	\$126.89	\$ 3,299.14
				\$ -
				\$ -
				\$ -
				\$ -
TOTAL LABOR COSTS				\$ 3,299.14
Material				
Description of Material	Quantity	Unit Price	Total	
See Attached	1	\$12,304.37	\$ 12,304.37	
			\$ -	
			\$ -	
			\$ -	
SUBTOTAL			\$ 12,304.37	
SALES TAX			\$ 1,199.68	
TOTAL MATERIAL COSTS				\$ 13,504.05
Equipment Rental				
Size & Type of Equipment	ID#	Hours	Rate	Total
				\$ -
				\$ -
				\$ -
TOTAL EQUIPMENT COSTS				\$ -
Lower Tier Trade Contractor(s) (attach all material receipts and T&M tags if applicable)				
Lower Tier Trade Contractor(s)	Quantity	Rate	Total	
			\$ -	
			\$ -	
TOTAL LOWER TIER TRADE CONTRACTOR(S) AMOUNT				\$ -
Total Cost				
TOTAL LABOR COST		\$	3,299.14	
12% Mark-Up		\$	395.90	
			Labor Cost	\$ 3,695.04
TOTAL MATERIAL COST		\$	13,504.05	
12% Mark-Up		\$	1,620.49	
			Material Cost	\$ 15,124.53
TOTAL EQUIPMENT COST		\$	-	
12% Mark-Up		\$	-	
			Equipment Cost	\$ -
TOTAL COST OF LOWER TIER TRADE CONTRACTOR(S)		\$	-	
12% Mark-Up		\$	-	
			Lower Tier Trade Contractor	\$ -
TOTAL COST OF CHANGE ORDER WORK				\$ 18,819.57
Trade Contractor Signature				

Date 1/20/2021

Title Project Manager

Print Name Gordon C Burwell II

Signature Gordon C Burwell II

CONFIDENTIAL - This document contains proprietary information of Sunflower Electric and neither this document nor any of said proprietary information shall be published, reproduced, copied, disclosed or used, in whole or in part, for any purposes without the express written permission of a duly authorized representative of Sunflower Electric.



Power Express

NEC Class 2 Shelf
 150028529 Shelf -48V input and output (unregulated)
 150036912 Shelf -48V input, -57V output (regulated)

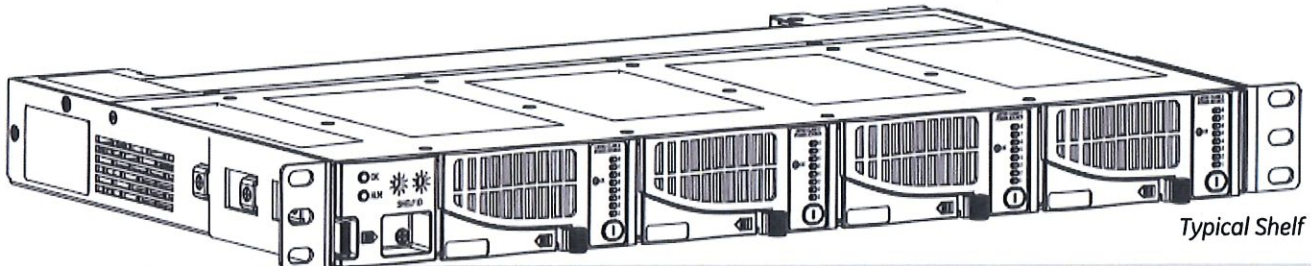

Read and follow all safety statements, warnings, and precautions in this guide.
 This shelf must be installed in a housing that prevents access to its top and sides and that provides unrestricted front to rear

Tools required:
 Cable crimpers Torque wrench (0-240 in-lb / 28 Nm) Sockets - 5/16," 7/16" and 1/2"
 Screw Drivers - Flat & 2 Phillips Wire cutters and strippers

Step 1 - Mount the Shelf

1. Remove non-conductive coating from the surface of frame/rack and apply antioxidant. Chassis is grounded by mounting system to frame/rack. Ensure the frame/rack is properly bounded.
2. Attach the system to the frame/rack using a minimum of 12 (six on each side) 12-24 screws (provided). Torque to 35 in-lb - 5/16" socket.

Step 2 - Connect Chassis Ground

- Wire - 6AWG minimum
- Lug - double-hole 1/4" on 5/8" centers (not provided).
- Secure lug with screws - 10-32 (provided)
 Torque to 10-32 screws to 30 in-lb (3.4Nm) - 5/16" socket.

Chassis Ground locations: Side location - all shelves; Rear location - 150028529 only.

Some applications may rely on frame mounting screws for shelf ground omitting the chassis ground cable.

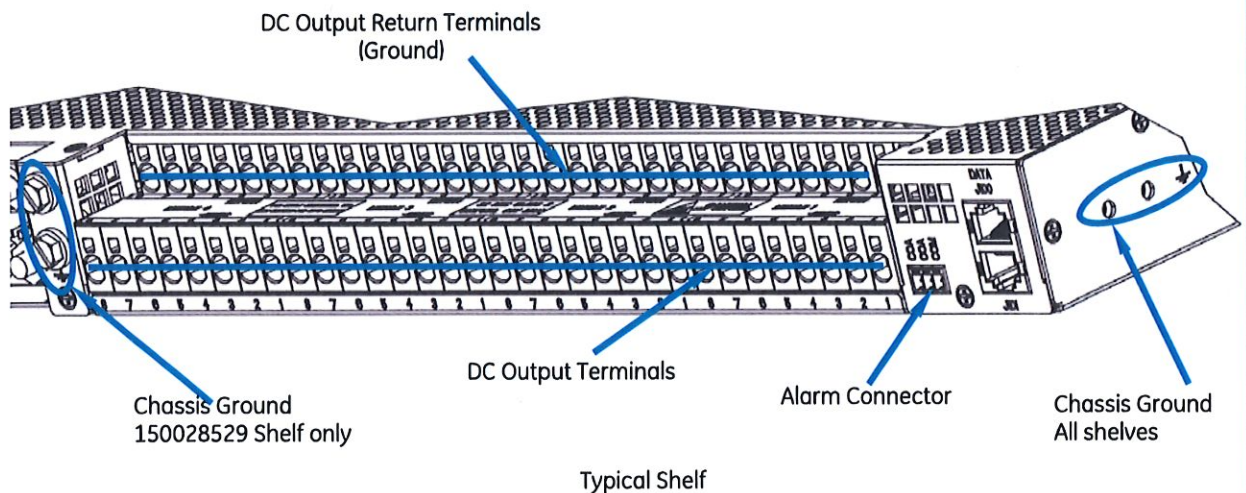

Step 3 - Connect DC Input Cables

- Wire - 1AWG minimum
- Lugs 1/4" on 5/8" centers (not provided).

Caution: Ensure cables do not come in contact with sharp or rough surfaces that may damage insulation and cause a short circuit.

External Feed Protector - Recommended		
Vin	Vin min.	Protector
-48V	-42V	100A
-57V	-57V	70A

150028529 Shelf

- Verify battery cable voltage and polarity.
- Connect to POS and NEG lug landings.
- Torque all lug nuts to 65 in-lb (7.3Nm) - 7/16" socket.

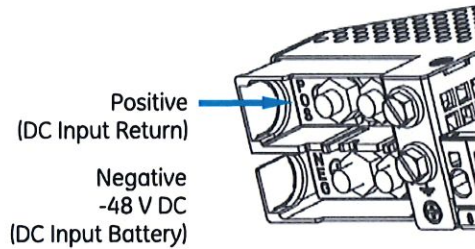

150036912 Shelf

Lug Bridging Buses are under lug nuts.

- Verify battery cable voltage and polarity.

Connect Negative feed cables

With Redundant Feed option - see note below.

- Remove NEG Lug Bridging Bus.
- Connect to NEGA and NEGB lug landings (2 cables).

Without Redundant Feed option

- Connect to NEGA or NEGB lug landing (1 cable).

Connect Positive feed cables

With Remote Output Reference option - see note below.

- Remove POS Lug Bridging Bus.
- Connect DC Input feed return to POSA lug landing.
- Connect Output Reference ground to POSB lug landing.

Without Remote Output Reference option

- Connect to NEGA or NEGB lug landing (1 cable).

Torque All Lug Nuts

- Torque all lug nuts to 65 in-lb (7.3Nm) - 7/16" socket.

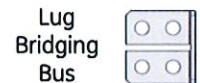
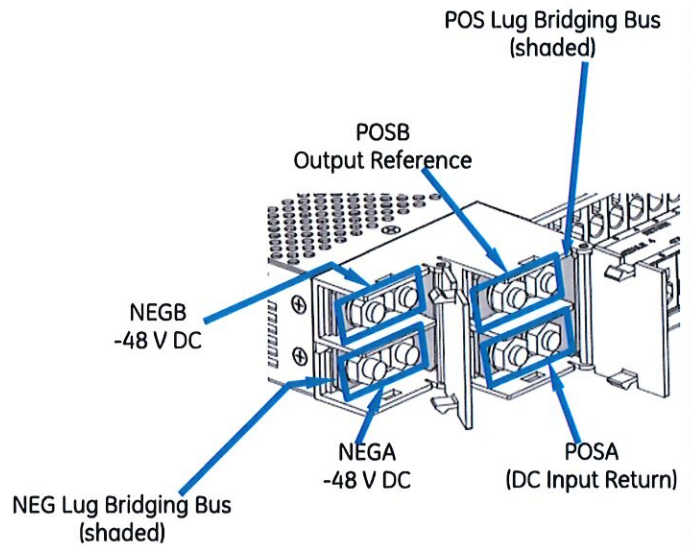

Notes: Apply these options only when directed by the site engineering instructions.

Redundant Feed requires that each feed be capable of powering the entire shelf when the other feed is unpowered. Both feeds must be protected as recommended in Step 5.

Remote Output Reference references the converter outputs to a point other than POSA (DC Input Return). When used, the reference is usually connected to a ground point near the powered equipment.

Step 4 - Verify DC Input Voltage and Polarity

- Verify that the DC Input voltage is -48VDC and matches the marked polarity using a meter.

Note: Equipment will operate properly only with proper DC Input voltage and polarity.

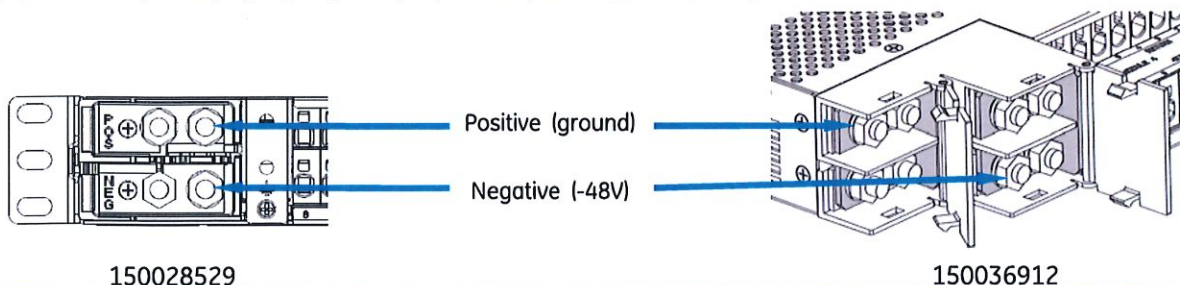

150028529

150036912





11505 DUBLIN BLVD UNIT 1
 DUBLIN CA 94568-2854
 Phone: 9255573046
 Fax: 925557

To: SUNFLOWER ELECTRIC
 1485 BAYSHORE BLVD, STE 423 MB196
 SAN FRANCISCO CA 94124-3002
 Attn: Matt McCombs
 Phone: 415-769-5590
 Fax: 844-294-3066
 Email: jsmithell@sunflowerelectric.net

Date: 01/14/2021
Proj Name: LAS POSITAS COLLEGE
GB Quote #: 0237038347
 Release Nbr:
 Purchase Order Nbr: LAS POSITAS COLLEGE
 Additional Ref#
 Valid From: 01/14/2021
 Valid To: 02/13/2021
 Contact: Brian Wallkvist
 Email: brian.wallkvist@graybar.com

Proposal

We Appreciate Your Request and Take Pleasure in Responding As Follows

Item	Item/Type	Quantity	Supplier	Catalog Nbr	Description	Price	Unit	Ext.Price
100	23 EA COMMSCOPE		PFP-SPS-1600M		EP-1600-UTEZ 48V REC 1200W-120 1500W-240	\$398.63	1	\$9,168.49
						13 =		5182.19
GB Part #: 26006684 UPC #: Ship From: Reship-Factory								
200	69 EA COMMSCOPE		PFP-PX-SF		PWR EXPRESS BLANK SLOT MOD	\$42.64	1	\$2,942.16
						39 =		1662.96
GB Part #: 26006682 UPC #: Ship From: Reship-Factory								
300	46 EA COMMSCOPE		PFP-SPS-SF		SPS RECT BLANK SLOT PANEL	\$11.49	1	\$528.54
						26 =		298.74
GB Part #: 26006686 UPC #: Ship From: Reship-Factory								
400	23 EA COMMSCOPE		PFP-SPS-S1		SPS RECTIFIER PWR DIST SHELF	\$396.96	1	\$9,130.08
						13 =		5160.48
GB Part #: 26006683 UPC #: Ship From: Reship-Factory								

Total in USD (Tax not included): ~~\$21,769.27~~
 12,304.37

This equipment and associated installation charges may be financed for a low monthly payment through Graybar Financial Services (subject to credit approval). For more information call 1-800-241-7408 to speak with a leasing specialist.

To learn more about Graybar, visit our website at www.graybar.com 24-Hour Emergency Phone#: 1-800-GRAYBAR

Subject to the standard terms and conditions set forth in this document. Unless otherwise noted, freight terms are F.O.B. shipping point prepaid and bill. Unless noted the estimated ship date will be determined at the time of order placement.

To: SUNFLOWER ELECTRIC
1485 BAYSHORE BLVD, STE 423 MB196
SAN FRANCISCO CA 94124-3002
Attn: Matt McCombs

Date: 01/14/2021
Proj Name: LAS POSITAS COLLEGE
GB Quote #: 0237038347

Proposal

We Appreciate Your Request and Take Pleasure in Responding As Follows

GRAYBAR ELECTRIC COMPANY INC. TERMS AND CONDITIONS OF SALE

- 1. ACCEPTANCE OF ORDER; TERMINATION** - Acceptance of any order is subject to credit approval and acceptance of order by Graybar Electric Company, Inc. ("Graybar") and, when applicable, Graybar's suppliers. If credit of the buyer of the goods or services ("Buyer") becomes unsatisfactory to Graybar, Graybar reserves the right to terminate upon notice to Buyer and without liability to Graybar.
- 2. PRICES AND SHIPMENTS** - Unless otherwise quoted, prices for goods shall be those in effect at time of shipment, which shall be made F.O.B. shipping point, prepaid and bill. Unless otherwise indicated in the applicable quotation or statement of work, prices for services shall be those in effect at the time of completion. The contract price for goods and or services shall be increased by the amount of any applicable tariff, excise, fee, assessment, levy, charge or duty of any kind whatsoever, imposed, assessed or collected by any governmental body, whether or not reflected in the costs charged to Graybar, and Graybar may increase its cost for goods and or services appropriately to take into account such increases in Graybar's costs.
- 3. RETURN OF GOODS** - Credit may be allowed for goods returned with prior approval. A deduction may be made from credits issued to cover cost of handling. Returns will not be accepted for services or any material which has been modified at the request of or by Buyer. In addition, no custom orders may be returned.
- 4. TAXES** - Prices shown do not include sales or other taxes imposed on the sale of goods or services. Taxes now or hereafter imposed upon sales, shipments or services will be added to the purchase price. Buyer agrees to reimburse Graybar for any such tax or provide Graybar with acceptable tax exemption certificate.
- 5. DELAY IN DELIVERY** - Graybar is not to be accountable for delays in delivery of goods or services occasioned by acts of God, failure of its suppliers to ship or deliver on time, or other circumstances beyond Graybar's reasonable control, including, but not limited to, sourcing, shipment or delivery issues caused by, related to or resulting from COVID-19 or other similar national or global health situations. Factory shipment or delivery dates are best estimates, and in no case shall Graybar be liable for any consequential or special damages arising from any delay in provision of services, shipment or delivery.
- 6. LIMITED WARRANTIES** - Graybar warrants that all goods sold are free of any security interest and will make available to Buyer all transferable warranties (including without limitation warranties with respect to intellectual property infringement) made to Graybar by the manufacturer of the goods. Buyer acknowledges that the performance of any service which alters the manufacturer provided goods as indicated in the statement of work may void the manufacturer's warranty. Graybar shall use the same care and skill a similarly situated provider of like services would exercise following commonly accepted industry practices in the performance of its duties under this agreement. **GRAYBAR MAKES NO OTHER EXPRESS OR IMPLIED WARRANTIES, AND SPECIFICALLY DISCLAIMS ALL IMPLIED WARRANTIES INCLUDING BUT NOT LIMITED TO THE IMPLIED WARRANTIES OF MERCHANTABILITY AND FITNESS FOR PURPOSE, UNLESS OTHERWISE AGREED IN WRITING BY AN AUTHORIZED REPRESENTATIVE OF GRAYBAR.** **PRODUCTS SOLD HEREUNDER ARE NOT INTENDED FOR USE IN OR IN CONNECTION WITH (1) ANY SAFETY APPLICATION OR THE CONTAINMENT AREA OF A NUCLEAR FACILITY, OR (2) IN A HEALTHCARE APPLICATION, WHERE THE GOODS HAVE POTENTIAL FOR DIRECT PATIENT CONTACT OR WHERE A SIX (6) FOOT CLEARANCE FROM A PATIENT CANNOT BE MAINTAINED AT ALL TIMES.**
- 7. LIMITATION OF LIABILITY** - Buyer's remedies under this agreement are subject to any limitations contained in manufacturer's terms and conditions to Graybar, a copy of which will be furnished upon written request. Furthermore, Graybar's liability shall be limited to either repair or replacement of the goods, re-performance of the services, or refund of the purchase price, all at Graybar's option, and **IN NO CASE SHALL GRAYBAR BE LIABLE FOR INCIDENTAL, SPECIAL, OR CONSEQUENTIAL DAMAGES.** In addition, claims for shortages, other than loss in transit, must be made in writing not more than five (5) days after receipt of shipment. Unless otherwise agreed in the applicable statement of work, acceptance of services will occur not more than five (5) days after completion of performance.
- 8. WAIVER** - The failure of Graybar to insist upon the performance of any of the terms or conditions of this agreement or to exercise any right hereunder shall not be deemed to be a waiver of such terms, conditions, or rights in the future, nor shall it be deemed to be a waiver of any other term, condition, or right under this agreement.
- 9. MODIFICATION OF TERMS AND CONDITIONS** - These terms and conditions, and any associated statement of work, supersede all other communications, negotiations, and prior oral or written statements regarding the subject matter of these terms and conditions. No change, modification, rescission, discharge, abandonment, or waiver of these terms and conditions shall be binding upon Graybar unless made in writing and signed on its behalf by a duly authorized representative of Graybar. No conditions, usage of trade, course of dealing or performance, understanding or agreement, purporting to modify, vary, explain, or supplement these terms and conditions shall be binding unless hereafter made in writing and signed by the party to be bound. Any proposed modifications or additional terms are specifically rejected and deemed a material alteration hereof. If this document shall be deemed an acceptance of a prior offer by Buyer, such acceptance is expressly conditional upon Buyer's assent to any additional or different terms set forth herein.
- 10. REBELS** - When Graybar ships returnable reels, a reel deposit may be included in the invoice. The Buyer should contact the nearest Graybar service location to return reels.
- 11. CERTIFICATION** - Graybar hereby certifies that these goods were produced in compliance with all applicable requirements of Sections 6, 7, and 12 of the Fair Labor Standards Act, as amended, and of regulations and orders of the United States Department of Labor issued under Section 14 thereof. This agreement is subject to Executive Order 11246, as amended, the Rehabilitation Act of 1973, as amended, the Vietnam Veterans' Readjustment Assistance Act of 1974, as amended, E.O. 13496, 29 CFR Part 471, Appendix A to Subpart A, and the corresponding regulations, to the extent required by law. 41 CFR 60-1.4, 60-741.5, and 60-250.5 are incorporated herein by reference, to the extent legally required.
- 12. FOREIGN CORRUPT PRACTICES ACT** - Buyer shall comply with applicable laws and regulations relating to anti-corruption, including, without limitation, (i) the United States Foreign Corrupt Practices Act (FCPA) (15 U.S.C. §§780d-1, et. seq.) irrespective of the place of performance, and (ii) laws and regulations implementing the Organization for Economic Cooperation and Development's Convention on Combating Bribery of Foreign Public Officials in International Business Transactions, the U.N. Convention Against Corruption, and the Inter-American Convention Against Corruption in Buyer's country or any country where performance of this agreement or delivery of goods will occur.
- 13. ASSIGNMENT** - Buyer shall not assign its rights or delegate its duties hereunder or any interest herein without the prior written consent of Graybar, and any such assignment, without such consent, shall be void.
- 14. GENERAL PROVISIONS** - All typographical or clerical errors made by Graybar in any quotation, acknowledgment or publication are subject to correction. This agreement shall be governed by the laws of the State of Missouri applicable to contracts to be formed and fully performed within the State of Missouri, without giving effect to the choice or conflicts of law provisions thereof. All suits arising from or concerning this agreement shall be filed in the Circuit Court of St. Louis County, Missouri, or the United States District Court for the Eastern District of Missouri, and no other place unless otherwise determined in Graybar's sole discretion. Buyer hereby irrevocably consents to the jurisdiction of such court or courts and agrees to appear in any such action upon written notice thereof.
- 15. PAYMENT TERMS** - Payment terms shall be as stated on Graybar's invoice or as otherwise mutually agreed. As a condition of the sales agreement, a monthly service charge of the lesser of 1-1/2% or the maximum permitted by law may be added to all accounts not paid by net due date. Visa, MasterCard, American Express, and Discover credit cards are accepted at point of purchase only.
- 16. EXPORTING** - Buyer acknowledges that this order and the performance thereof are subject to compliance with any and all applicable United States laws, regulations, or orders. Buyer agrees to comply with all such laws, regulations, and orders, including, if applicable, all requirements of the International Traffic in Arms Regulations and/or the Export Administration Act, as may be amended. Buyer further agrees that if the export laws are applicable, it will not disclose or re-export any technical data received under this order to any countries for which the United States government requires an export license or other supporting documentation at the time of export or transfer, unless Buyer has obtained prior written authorization from the United States Office of Export Control or other authority responsible for such matters.
- 17. CANCELLATION; CHANGES FOR SERVICES** - Buyer may cancel or make changes to a statement of work up to five (5) business days prior to commencement of the work. All changes and cancellations after such date are subject to Graybar's prior written approval in Graybar's sole and absolute discretion. Buyer shall pay to Graybar amounts necessary to cover cancellation, restocking fees and other charges applicable to the cancelled goods or services including those incurred or committed to by Graybar.

Signed: _____

This equipment and associated installation charges may be financed for a low monthly payment through Graybar Financial Services (subject to credit approval). For more information call 1-800-241-7408 to speak with a leasing specialist.

To learn more about Graybar, visit our website at www.graybar.com

24-Hour Emergency Phone#: 1-800-GRAYBAR

Subject to the standard terms and conditions set forth in this document. Unless otherwise noted, freight terms are F.O.B. shipping point prepaid and bill. Unless noted the estimated ship date will be determined at the time of order placement.

Sunflower Electric

1485 Bayshore Blvd #196, Suite 406
San Francisco, CA 94124
Ph 415-859-5554

CHANGE ORDER

To:	
Customer	<u>Electronic Innovations</u>
Address	<u>21 Parr Blvd</u>
City	<u>Richmond</u> CA <u>94801</u>
Attn:	<u>Adam Henricksen</u>

Date	<u>12/8/2020</u>
Job #	<u>S704</u>
C/O #	<u>18001</u>
Contract	<u></u>
PCO #	<u></u>

Project:

Chabot - Las Positas Colleges

Mr./Mrs. Adam Henricksen

We are pleased to provide this proposal for the subject project. Please see the following scope of work.

Scope:

F/I Rectifier components per Sunflower RFI - 001, identified by Commscope representative Mungree Singh.

Exclusions/Clarifications:

1 - All base bid exclusions and clarifications apply.

Total Pricing:

Sincerely,

Gordon C Burwell II

Gordon C Burwell II
Project Manager
Sunflower Electric
GBurwell@SunflowerElectric.net
C: (650) 281-9181
O: (415) 859-5554

\$ **\$16,619.36 pricing on Sunflowers' PCO.**

(+ additional 5% for Electronic Innovations Over Head and 1% for Electronic Innovations Bond

Total expected PCO with GC overhead bond for both campuses combined = approximately **\$17,616.51)**

Sunflower Electric

1485 Bayshore Blvd #196, Suite 406
 San Francisco, CA 94124
 Ph 415-859-5554

CHANGE ORDER

TRADE CONTRACTOR COST PROPOSAL FORM

This form is to be completed by each trade contractor and each lower tier trade contractor. Use additional sheets as necessary.

San Francisco International Airport

Contract No:	0	Date:	12/8/2020
Project Name:	Chabot - Las Positas Colleges		
Trade Contractor Name:		Trade Contractor	
HRC% of Change:		RFI/Subr	
Description of Work			
See Page One: Scope			

Estimated work to install modules is under 30 minutes. 7 hours should be more than enough time.

Labor				
Name	Classification	Hours	Rate	Total
	Senior Tech	7	\$126.89	\$888.23
TOTAL LABOR COSTS				\$ 11,672.88

7hrx \$126 = \$888.23

Material				
Description of Material	Quantity	Unit Price	Total	
See Attached		\$12,711.14	\$	\$12,711.14
			\$	-
			\$	-
			\$	-
SUBTOTAL				\$ 12,711.14
SALES TAX				\$ 1,239.34 (@ 9.75% tax)
TOTAL MATERIAL COSTS				\$ 13,950.48

See notes on next page re: # of units and unit cost.

Truck expense already included in overhead per 01 26 00 1.08

Equipment Rental				
Size & Type of Equipment	ID#	Hours	Rate	Total
Truck - Per DOT/Caltrans Surcharge/Rental Rates 2020	20	12	22	3,604.72
TOTAL EQUIPMENT COSTS				\$ 3,604.72

Lower Tier Trade Contractor(s) (attach all material receipts and T&M tags if applicable)			
Lower Tier Trade Contractor(s)	Quantity	Rate	Total
			\$ -
			\$ -
TOTAL LOWER TIER TRADE CONTRACTOR(S) AMOUNT			\$ -

Markup is capped at 12% for the sub - 5% for the GC

Total Cost				
TOTAL LABOR COST		\$ 11,672.88		\$888.23
35% Mark-Up		\$ 4,085.86		\$106.59 (.12x\$888.23)
TOTAL MATERIAL COST		\$ 13,950.48		\$994.82
15% Mark-Up		\$ 1,674.06		
TOTAL EQUIPMENT COST		\$ 3,604.72		\$15,624.54
15% Mark-Up		\$ 534.21		
TOTAL COST OF LOWER TIER TRADE CONTRACTOR(S)		\$ -		\$ -
5% Mark-Up		\$ -		\$ -
Lower Tier Trade Contractor				\$ -

See notes on next page re: unit cost.

What additional equipment is needed for rental that isn't already used in base bid work? If there is said equipment, provide back up.

TOTAL COST OF CHANGE ORDER WORK	\$ 16,619.36
Trade Contractor Signature	

Date 12/8/2020 Title Project Manager

Print Name Gordon C Burwell II Signature Gordon C Burwell II

CONFIDENTIAL - This document contains proprietary information of Sunflower Electric and neither this document nor any of said proprietary information shall be published, reproduced, copied, disclosed or used, in whole or in part, for any purposes without the express written permission of a duly authorized representative of Sunflower Electric.



11505 DUBLIN BLVD UNIT 1
 DUBLIN CA 94568-2854
 Phone: 9255573046
 Fax: 925557

To: SUNFLOWER ELECTRIC
 1485 BAYSHORE BLVD, STE 423 MB196
 SAN FRANCISCO CA 94124-3002
 Attn: Gordon Burwell
 Phone: 415-769-5590
 Fax: 844-294-3066
 Email: brian.wallkvist@graybar.com

Date: 12/04/2020
 Proj Name: SUNFLOWER
 GB Quote #: 0236795575
 Release Nbr:
 Purchase Order Nbr: SUNFLOWER
 Additional Ref#
 Valid From: 12/04/2020
 Valid To: 01/03/2021
 Contact: Brian Wallkvist
 Email: brian.wallkvist@graybar.com

Proposal

We Appreciate Your Request and Take Pleasure in Responding As Follows

Item	Item/Type	Quantity	Supplier	Catalog Nbr	Description	Ext.Price
<div style="border: 1px solid red; padding: 2px;"> Graybar non-discounted retail pricing is below </div>						
100	23 EA COMMSCOPE			PFP-SPS-1600M	EP-1600-UTEZ 48V REC 1200W-120 1500W-240	\$165.07 1 \$10,606.61
<div style="border: 1px solid red; padding: 2px;"> 13 (Where did these quantities come from? Per engineer only 9 @ LPC 4 @ Chabot are needed) </div>						<div style="border: 1px solid red; padding: 2px;"> $\\$401.70 \times 13ea = \\$5,222.10$ (please note \$401 is Graybar retail (website) pricing, we expect the price to CLPCCD should be \$50 cheaper than retail because cabling contractors get substantial discounts from Graybar) </div>
GB Part #: 26006684 Ship From: Res						
200	69 EA COMMSCOPE			PFP-PX-SF	PWR EXPRESS BLANK SLOT MOD	\$49.75 1 \$3,432.75
<div style="border: 1px solid red; padding: 2px;"> 39 (13x3) </div>						<div style="border: 1px solid red; padding: 2px;"> $\\$49.75 \times 39 = \\$1,940.25$ </div>
GB Part #: 26006682 Ship From: Reship-Factory						
300	46 EA COMMSCOPE			PFP-SPS-SF	SPS RECT BLANK SLOT PANEL	\$13.40 1 \$616.40
<div style="border: 1px solid red; padding: 2px;"> 26 (13x2) </div>						<div style="border: 1px solid red; padding: 2px;"> $\\$13.40 \times 26 = \\348.40 </div>
GB Part #: 26006686 Ship From: Reship-Factory						
400	29 EA COMMSCOPE			PFP-SPS-S1	SPS RECTIFIER PWR DIST SHELF	\$400.12 1 \$10,651.76
<div style="border: 1px solid red; padding: 2px;"> 13 (9 @ LPC 4 @ Chabot) </div>						<div style="border: 1px solid red; padding: 2px;"> $\\$400.03 \times 13ea = \\$5,200.39$ </div>
GB Part #: 26006683 Ship From: Reship-Factory						

Total in USD (Tax not included): \$12,711.14

This equipment and associated installation charges may be financed for a low monthly payment through Graybar Financial Services (subject to credit approval). For more information call 1-800-241-7408 to speak with a leasing specialist.

To learn more about Graybar, visit our website at www.graybar.com 24-Hour Emergency Phone#: 1-800-GRAYBAR

Subject to the standard terms and conditions set forth in this document. Unless otherwise noted, freight terms are F.O.B. shipping point prepaid and bill. Unless noted the estimated ship date will be determined at the time of order placement.

To: SUNFLOWER ELECTRIC
1485 BAYSHORE BLVD, STE 423 MB196
SAN FRANCISCO CA 94124-3002
Attn: Gordon Burwell

Date: 12/04/2020
Proj Name: SUNFLOWER
GB Quote #: 0236795575

Proposal

We Appreciate Your Request and Take Pleasure in Responding As Follows

GRAYBAR ELECTRIC COMPANY, INC. TERMS AND CONDITIONS OF SALE

1. **ACCEPTANCE OF ORDER; TERMINATION** - Acceptance of any order is subject to credit approval and acceptance of order by Graybar Electric Company, Inc. ("Graybar") and, when applicable, Graybar's suppliers. If credit of the buyer of the goods or services ("Buyer") becomes unsatisfactory to Graybar, Graybar reserves the right to terminate upon notice to Buyer and without liability to Graybar.
2. **PRICES AND SHIPMENTS** - Unless otherwise quoted, prices for goods shall be those in effect at time of shipment, which shall be made F.O.B. shipping point, prepaid and bill. Unless otherwise indicated in the applicable quotation or statement of work, prices for services shall be those in effect at the time of completion. The contract price for goods and or services shall be increased by the amount of any applicable tariff, excise, fee, assessment, levy, charge or duty of any kind whatsoever, imposed, assessed or collected by any governmental body, whether or not reflected in the costs charged to Graybar, and Graybar may increase its cost for goods and or services appropriately to take into account such increases in Graybar's costs.
3. **RETURN OF GOODS** - Credit may be allowed for goods returned with prior approval. A deduction may be made from credits issued to cover cost of handling. Returns will not be accepted for services or any material which has been modified at the request of or by Buyer. In addition, no custom orders may be returned.
4. **TAXES** - Prices shown do not include sales or other taxes imposed on the sale of goods or services. Taxes now or hereafter imposed upon sales, shipments or services will be added to the purchase price. Buyer agrees to reimburse Graybar for any such tax or provide Graybar with acceptable tax exemption certificate.
5. **DELAY IN DELIVERY** - Graybar is not to be accountable for delays in delivery of goods or services occasioned by acts of God, failure of its suppliers to ship or deliver on time, or other circumstances beyond Graybar's reasonable control, including, but not limited to, sourcing, shipment or delivery issues caused by, related to or resulting from COVID-19 or other similar national or global health situations. Factory shipment or delivery dates are best estimates, and in no case shall Graybar be liable for any consequential or special damages arising from any delay in provision of services, shipment or delivery.
6. **LIMITED WARRANTIES** - Graybar warrants that all goods sold are free of any security interest and will make available to Buyer all transferable warranties (including without limitation warranties with respect to intellectual property infringement) made to Graybar by the manufacturer of the goods. Buyer acknowledges that the performance of any service which alters the manufacturer provided goods as indicated in the statement of work may void the manufacturer's warranty. Graybar shall use the same care and skill a similarly situated provider of like services would exercise following commonly accepted industry practices in the performance of its duties under this agreement. **GRAYBAR MAKES NO OTHER EXPRESS OR IMPLIED WARRANTIES, AND SPECIFICALLY DISCLAIMS ALL IMPLIED WARRANTIES INCLUDING BUT NOT LIMITED TO THE IMPLIED WARRANTIES OF MERCHANTABILITY AND FITNESS FOR PURPOSE, UNLESS OTHERWISE AGREED IN WRITING BY AN AUTHORIZED REPRESENTATIVE OF GRAYBAR.** PRODUCTS SOLD HEREUNDER ARE NOT INTENDED FOR USE IN OR IN CONNECTION WITH (1) ANY SAFETY APPLICATION OR THE CONTAINMENT AREA OF A NUCLEAR FACILITY, OR (2) IN A HEALTHCARE APPLICATION, WHERE THE GOODS HAVE POTENTIAL FOR DIRECT PATIENT CONTACT OR WHERE A SIX (6) FOOT CLEARANCE FROM A PATIENT CANNOT BE MAINTAINED AT ALL TIMES.
7. **LIMITATION OF LIABILITY** - Buyer's remedies under this agreement are subject to any limitations contained in manufacturer's terms and conditions to Graybar, a copy of which will be furnished upon written request. Furthermore, Graybar's liability shall be limited to either repair or replacement of the goods, re-performance of the services, or refund of the purchase price, all at Graybar's option, and IN NO CASE SHALL GRAYBAR BE LIABLE FOR INCIDENTAL, SPECIAL, OR CONSEQUENTIAL DAMAGES. In addition, claims for shortages, other than loss in transit, must be made in writing not more than five (5) days after receipt of shipment. Unless otherwise agreed in the applicable statement of work, acceptance of services will occur not more than five (5) days after completion of performance.
8. **WAIVER** - The failure of Graybar to insist upon the performance of any of the terms or conditions of this agreement or to exercise any right hereunder shall not be deemed to be a waiver of such terms, conditions, or rights in the future, nor shall it be deemed to be a waiver of any other term, condition, or right under this agreement.
9. **MODIFICATION OF TERMS AND CONDITIONS** - These terms and conditions, and any associated statement of work, supersedes all other communications, negotiations, and prior oral or written statements regarding the subject matter of these terms and conditions. No change, modification, rescission, discharge, abandonment, or waiver of these terms and conditions shall be binding upon Graybar unless made in writing and signed on its behalf by a duly authorized representative of Graybar. No conditions, usage of trade, course of dealing or performance, understanding or agreement, purporting to modify, vary, explain, or supplement these terms and conditions shall be binding unless hereafter made in writing and signed by the party to be bound. Any proposed modifications or additional terms are specifically rejected and deemed a material alteration hereof. If this document shall be deemed an acceptance of a prior offer by Buyer, such acceptance is expressly conditional upon Buyer's assent to any additional or different terms set forth herein.
10. **REELS** - When Graybar ships returnable reels, a reel deposit may be included in the invoice. The Buyer should contact the nearest Graybar service location to return reels.
11. **CERTIFICATION** - Graybar hereby certifies that these goods were produced in compliance with all applicable requirements of Sections 6, 7, and 12 of the Fair Labor Standards Act, as amended, and of regulations and orders of the United States Department of Labor issued under Section 14 thereof. This agreement is subject to Executive Order 11246, as amended, the Rehabilitation Act of 1973, as amended, the Vietnam Veterans' Readjustment Assistance Act of 1974, as amended, E.O. 13496, 29 CFR Part 471, Appendix A to Subpart A, and the corresponding regulations, to the extent required by law, 41 CFR 60-1.4, 60-741.5, and 60-250.5 are incorporated herein by reference, to the extent legally required.
12. **FOREIGN CORRUPT PRACTICES ACT** - Buyer shall comply with applicable laws and regulations relating to anti-corruption, including, without limitation, (i) the United States Foreign Corrupt Practices Act (FCPA) (15 U.S.C. §§78dd-1, et. seq.) irrespective of the place of performance, and (ii) laws and regulations implementing the Organization for Economic Cooperation and Development's Convention on Combating Bribery of Foreign Public Officials in International Business Transactions, the U.N. Convention Against Corruption, and the Inter-American Convention Against Corruption in Buyer's country or any country where performance of this agreement or delivery of goods will occur.
13. **ASSIGNMENT** - Buyer shall not assign its rights or delegate its duties hereunder or any interest herein without the prior written consent of Graybar, and any such assignment, without such consent, shall be void.
14. **GENERAL PROVISIONS** - All typographical or clerical errors made by Graybar in any quotation, acknowledgment or publication are subject to correction. This agreement shall be governed by the laws of the State of Missouri applicable to contracts to be formed and fully performed within the State of Missouri, without giving effect to the choice or conflicts of law provisions thereof. All suits arising from or concerning this agreement shall be filed in the Circuit Court of St. Louis County, Missouri, or the United States District Court for the Eastern District of Missouri, and no other place unless otherwise determined in Graybar's sole discretion. Buyer hereby irrevocably consents to the jurisdiction of such court or courts and agrees to appear in any such action upon written notice thereof.
15. **PAYMENT TERMS** - Payment terms shall be as stated on Graybar's invoice or as otherwise mutually agreed. As a condition of the sales agreement, a monthly service charge of the lesser of 1-1/2% or the maximum permitted by law may be added to all accounts not paid by net due date. Visa, MasterCard, American Express, and Discover credit cards are accepted at point of purchase only.
16. **EXPORTING** - Buyer acknowledges that this order and the performance thereof are subject to compliance with any and all applicable United States laws, regulations, or orders. Buyer agrees to comply with all such laws, regulations, and orders, including, if applicable, all requirements of the International Traffic in Arms Regulations and/or the Export Administration Act, as may be amended. Buyer further agrees that if the export laws are applicable, it will not disclose or re-export any technical data received under this order to any countries for which the United States government requires an export license or other supporting documentation at the time of export or transfer, unless Buyer has obtained prior written authorization from the United States Office of Export Control or other authority responsible for such matters.
17. **CANCELLATION; CHANGES FOR SERVICES** - Buyer may cancel or make changes to a statement of work up to five (5) business days prior to commencement of the work. All changes and cancellations after such date are subject to Graybar's prior written approval in Graybar's sole and absolute discretion. Buyer shall pay to Graybar amounts necessary to cover cancellation, restocking fees and other charges applicable to the cancelled goods or services including those incurred or committed to by Graybar.

Signed: _____

This equipment and associated installation charges may be financed for a low monthly payment through Graybar Financial Services (subject to credit approval). For more information call 1-800-241-7408 to speak with a leasing specialist.

To learn more about Graybar, visit our website at www.graybar.com

24-Hour Emergency Phone#: 1-800-GRAYBAR

Subject to the standard terms and conditions set forth in this document. Unless otherwise noted, freight terms are F.O.B. shipping point prepaid and bill.

Unless noted the estimated ship date will be determined at the time of order placement.



REQUEST FOR INFORMATION

TO: Electronic Innovations
211 Parr Blvd
Richmond, CA 94801
Attn: Daryl Barth

R.F.I. #: 001

DATED: 11/25/20

FROM: _____

DATE INFORMATION REQUIRED: 12/1/20

SUBJECT: Unlisted Components

PRIORITY:
 ROUTINE
 EXPEDITE
 URGENT

CATEGORY:

- INFORMATION NOT SHOWN ON CONTRACT DOCS.
- INTERPRETATION OF CONTRACT REQUIREMENTS
- CONFLICT IN CONTRACT REQUIREMENTS
- COORDINATION PROBLEM

CONTRACT DRAWING REF. _____
SHOP DRAWING REF. _____
SPECIFICATION REF. 27.15.23-2.02

- POSSIBLE COST IMPACT
- POSSIBLE TIME IMPACT

Please note after system consultation with Commscope representative several additional components are necessary in order to deliver full complete working system. Following items not listed in specification sections: Commscope PFP-SPS-1600M, PFP-PX-SF, PFP-SPS-SF, PFP-SPS-S1. Pricing and schedule impacts to follow.
Please also confirm/approve attached commscope items.

THIS RFI REPRESENTS WORK THAT WE ARE NOT ABLE TO PROCEED WITH AT THIS TIME UNTIL A RESPONSE IS FORWARDED FROM YOUR OFFICE
 THIS RFI REPRESENTS WORK BEYOND OUR CURRENT CONTRACT SCOPE. SIGN WHERE INDICATED BELOW IF YOU WOULD LIKE US TO PROCEED. PRICING TO FOLLOW.
AGREED: _____ **DATE:** _____

REPLY:

COPY TO:

- GENERAL CONTRACTOR
- ENGINEER
- SUPERINTENDENT
- PROJECT MANAGER
- AREA MANAGER
- PURCHASING

ANSWERED BY: _____
DATE: _____

Sunflower Electric
1485 Bayshore Blvd Suite 406 MB 196
San Francisco, CA 94124
415-859-5554



REQUEST FOR INFORMATION

E.I. RFI#	003	DATE:	11/30/2020	PROJECT:	Chabot/Los Positas
------------------	-----	--------------	------------	-----------------	--------------------

TO: <u>Swinerton</u>	FROM: <u>Daryl Barth</u>
ATTN: <u>Michael Stroud</u>	TITLE: <u>Project Manager</u>
PHONE: <u>4155178970</u>	PHONE: <u>(510) 965-5292</u>
EMAIL: <u>mstroud@swinerton.com</u>	EMAIL: <u>dbarth@electronicinnovations.com</u>
FAX: _____	FAX: <u>510-232-3205</u>

QUESTION

BY: <u>Daryl Barth</u>	DRWNG/REF.: _____
SUBJECT: <u>Copper wireway questions</u>	LOCATION: <u>Chabot/Los Positas</u>

QUESTION:

Please note after our subcontractor, Sunflower Electric's system consultation with Commscope representatives it was determined that several additional components are necessary in order to deliver full complete working system. Following items are not listed in specification sections: Commscope PFP-SPS1600M, PFP-PX-SF, PFP-SPS-SF, PFP-SPS-S1. Pricing and schedule impacts to follow. Please also confirm/approve attached Commscope items.

RESPONSE

BY: _____

RESPONSE:

ACCEPTED: _____

Y/N	SIGNATURE	DATE
-----	-----------	------

Attachment 1

From: Singh, Mungree <Mungree.Singh@commscope.com>
Sent: Monday, November 16, 2020 3:58 PM
To: Matt McCombs
Cc: Michael Gaines; Gordon Burwell; Crowe, Kevin; Raaker, Jeff
Subject: RE: BOM for LPC and Chabot
Attachments: PFC Presentation.pdf; Powerr Express Quick Start Guide.pdf; PFCS Discrete Power Cycling Application Note.pdf; PFCS Power Supply Connection Application Note.pdf; PFCS Sample BOM.xls

Hello Matt,

It was a pleasure meeting you all as well.

Line item 401 is an incorrect part number. For a splice tray that will work with the HD-2U panel please use 760031856 | RS-4AF-16SF

<https://www.commscope.com/product-type/cabinets-panels-enclosures/fiber-panels-cassettes/fiber-splice-trays-wallets/item760031856/>

Please replace all Corning items with a CommScope part number. Corning items are not approved.

Line 500 – replace with 9701008/00 Fiber Optic Single Fusion Splice Sleeve, 50 Pack

Line 800 – replace with 760248900 760248900 | WB2-EMT-BK-1P-MOD

<https://www.commscope.com/product-type/cabinets-panels-enclosures/wall-boxes-accessories/wall-boxes/item760248900/> Do you need an LC or SC adapter or splice cassette at this location?

Where is this being used? <https://www.commscope.com/search/?searchquery=108009432>

108009432 | M81C-COUPLER

~~M81C Coaxial Coupler~~

I do not see any of the items for the Rectifier shelf and the blanks for the power shelf. See items below.

PFP-SPS-1600M <https://www.commscope.com/search/?searchquery=PFP-SPS-1600M>

PFP-SPS-S1 <https://www.commscope.com/product-type/networking-systems/powered-fiber-cable-systems/dc-power-supplies/itempfp-sps-s1/>

PFP-PX-SF <https://www.commscope.com/product-type/networking-systems/powered-fiber-cable-systems/dc-power-supplies/itempfp-px-sf/>

PFP-SPS-SF <https://www.commscope.com/product-type/networking-systems/powered-fiber-cable-systems/dc-power-supplies/itempfp-sps-sf/>

Items highlighted on the PFCS Sample BOM is what shows up on your current quote. Other items is required.

The SFP should be E1MG-LX-OM. The quote has an incorrect part number.

I am available tomorrow to answer any questions.

Respectfully,
M~

Mungree Singh, MBA, RCDD, CBRS - CPI
Technical Manager ISE | Enterprise
Venue and Campus

COMMSCOPE

"Glad to be here. Better together"!

Now meets next

Cupertino, CA 95014, USA

Mobile: +1-408-444-1249

Follow me on LinkedIn

[Learn how CommScope is shaping the networks of the future](#)



We are a 2020 Gartner Peer Insights Customers' Choice for Wired and Wireless LAN Access Infrastructure

Reviews from your enterprise peers -- verified by Gartner

[See what our users have to say](#)

[Contribute a review today](#)